



Beam Moving Head  
B5R  
moving head

Musikhaus Thomann  
Thomann GmbH  
Hans-Thomann-Straße 1  
96138 Burgebrach  
Germany  
Telephone: +49 (0) 9546 9223-0  
E-mail: [info@thomann.de](mailto:info@thomann.de)  
Internet: [www.thomann.de](http://www.thomann.de)

21.12.2015, ID: 347665

# Table of contents

<b>1</b>	<b>General notes</b> .....	<b>5</b>
	1.1 Further information.....	6
	1.2 Notational conventions.....	7
	1.3 Symbols and signal words.....	8
<b>2</b>	<b>Safety instructions</b> .....	<b>11</b>
<b>3</b>	<b>Features</b> .....	<b>20</b>
<b>4</b>	<b>Installation</b> .....	<b>21</b>
<b>5</b>	<b>Starting up</b> .....	<b>27</b>
<b>6</b>	<b>Connections and operating elements</b> .....	<b>30</b>
<b>7</b>	<b>Operating</b> .....	<b>33</b>
	7.1 Starting the device.....	33
	7.2 Main menu.....	34
	7.3 Gobos.....	45
	7.4 Menu overview.....	47
	7.5 Functions in 16-channel DMX mode.....	48

7.6	Functions in 17-channel DMX mode.....	57
<b>8</b>	<b>Maintenance.....</b>	<b>67</b>
8.1	Installing / replacing the illuminant.....	67
8.2	Lamp hour counter reset.....	78
<b>9</b>	<b>Technical specifications.....</b>	<b>79</b>
<b>10</b>	<b>Plug and connection assignment.....</b>	<b>80</b>
<b>11</b>	<b>Troubleshooting.....</b>	<b>81</b>
<b>12</b>	<b>Cleaning.....</b>	<b>83</b>
<b>13</b>	<b>Protecting the environment.....</b>	<b>84</b>

# 1 General notes

This manual contains important instructions for the safe operation of the unit. Read and follow the safety instructions and all other instructions. Keep the manual for future reference. Make sure that it is available to all those using the device. If you sell the unit please make sure that the buyer also receives this manual.

Our products are subject to a process of continuous development. Thus, they are subject to change.

## 1.1 Further information

On our website ([www.thomann.de](http://www.thomann.de)) you will find lots of further information and details on the following points:

Download	This manual is also available as PDF file for you to download.
Keyword search	Use the search function in the electronic version to find the topics of interest for you quickly.
Online guides	Our online guides provide detailed information on technical basics and terms.
Personal consultation	For personal consultation please contact our technical hotline.
Service	If you have any problems with the device the customer service will gladly assist you.

## 1.2 Notational conventions

This manual uses the following notational conventions:

### Letterings

The letterings for connectors and controls are marked by square brackets and italics.

**Examples:** *[VOLUME]* control, *[Mono]* button.

### Displays

Texts and values displayed on the device are marked by quotation marks and italics.

**Examples:** *'24ch'*, *'OFF'*.

### Cross-references

References to other locations in this manual are identified by an arrow and the specified page number. In the electronic version of the manual, you can click the cross-reference to jump to the specified location.





Example: See ↗ *'Cross-references'* on page 7.

### 1.3 Symbols and signal words

In this section you will find an overview of the meaning of symbols and signal words that are used in this manual.

Signal word	Meaning
<b>DANGER!</b>	This combination of symbol and signal word indicates an immediate dangerous situation that will result in death or serious injury if it is not avoided.
<b>WARNING!</b>	This combination of symbol and signal word indicates a possible dangerous situation that can result in death or serious injury if it is not avoided.
<b>CAUTION!</b>	This combination of symbol and signal word indicates a possible dangerous situation that can result in minor injury if it is not avoided.
<b>NOTICE!</b>	This combination of symbol and signal word indicates a possible dangerous situation that can result in material and environmental damage if it is not avoided.



Warning signs	Type of danger
	Warning – high-voltage.
	Warning – hot surface.
	Warning – dangerous optical radiation.
	Warning – suspended load.
	Warning – toxic substances.

Warning signs	Type of danger
	Warning – danger zone.

## 2 Safety instructions

### Intended use

This device is intended to be used as moving-head spotlight. The device is designed for professional use and is not suitable for use in households. Use the device only as described in this user manual. Any other use or use under other operating conditions is considered to be improper and may result in personal injury or property damage. No liability will be assumed for damages resulting from improper use.

This device may be used only by persons with sufficient physical, sensorial, and intellectual abilities and having corresponding knowledge and experience. Other persons may use this device only if they are supervised or instructed by a person who is responsible for their safety.

### Safety



#### **DANGER!**

##### **Danger for children**

Ensure that plastic bags, packaging, etc. are disposed of properly and are not within reach of babies and young children. Choking hazard!

Ensure that children do not detach any small parts (e.g. knobs or the like) from the unit. They could swallow the pieces and choke!

Never let children unattended use electrical devices.



#### **DANGER!**

##### **Electric shock caused by high voltages inside**

Within the device there are areas where high voltages may be present.

Completely disconnect the device from the power supply before you open or remove covers. Mount all covers and attach them firmly before connecting the device again.



**DANGER!**

**Electric shock caused by short-circuit**

Always use proper ready-made insulated mains cabling (power cord) with a protective contact plug. Do not modify the mains cable or the plug. Failure to do so could result in electric shock/death or fire. If in doubt, seek advice from a registered electrician.



**WARNING!**

**Risk of epileptic shock**

Strobe lighting can trigger seizures in photosensitive epilepsy. Sensitive persons should avoid looking at strobe lights.



**WARNING!**

**Danger of burns and eye injuries caused by high light intensity**

The light source used in this device produces visible and invisible light beams of high intensity.

Never look directly into the light source.

Do not use the device when covers, shieldings, lenses or other optical components are missing or damaged. In particular, avoid prolonged direct exposure of the skin during maintenance without adequate cover of the light source.



**WARNING!**

**Risk of burns**

The surface of the device can become very hot during operation.

Do not touch the device with bare hands during operation, and after switching off wait for at least 15 minutes.



**WARNING!**

**Danger of burns in case of inappropriate handling of the illuminant**

The light source used in this device is under high pressure, especially when heated, and can explode if handled inappropriately.

Allow the illuminant to cool down for at least two hours before starting any maintenance or replacement. Always wear suitable protective gloves and safety glasses when handling the illuminant.



**WARNING!**

**Danger of poisoning on lamp breakage**

When discharge lamps break, small amounts of harmful substances (e.g. mercury) are released.

When a discharge lamp breaks within a closed room: Vacate the room immediately and ventilate adequately.

To remove the remnants of broken discharge lamps wear Nitrile protective gloves, breathing and mouth protection.

Dispose of broken or worn discharge lamps as hazardous waste according to legal regulations in a tightly closed container.



**WARNING!**

**Risk of injury caused by falling objects**

Make sure that the installation complies with the standards and rules that apply in your country. Always secure the device with a secondary safety attachment, such as a safety cable or a safety chain.





**CAUTION!**

**Risk of injury due to movements of the device**

The head of the device can move quickly (pan, tilt) and can produce very bright light. This is also valid immediately after you turn on the device, when the device operates in automatic mode or under remote control and when you turn off a DMX controller that is connected to the device. Persons staying near the device could be injured or frightened.

Before you turn on the device and during the operation, always ensure that nobody stays close to the device. If work has to be performed in the area of movement or in the near vicinity of the device, it must remain turned off.



**CAUTION!**

**Danger of injury in case of inappropriate handling of the illuminant**

After the specified lifetime of the used illuminant there is an increased risk of explosion.

Replace the illuminant in time, latest at the end of rated average lifetime.

When replacing the illuminant, all safety instructions for handling light sources must be observed and wear suitable protective gloves and safety glasses.



**NOTICE!**

**Risk of fire**

Do not cover the device nor any ventilation slots. Do not place the device near any direct heat source. Keep the device away from naked flames.



**NOTICE!**

**Operating conditions**

This device has been designed for indoor use only. To prevent damage, never expose the device to any liquid or moisture. Avoid direct sunlight, heavy dirt, and strong vibrations.

The device must not be moved while it is in use.



**NOTICE!**

**Power supply**

Before connecting the device, ensure that the input voltage (AC outlet) matches the voltage rating of the device and that the AC outlet is protected by a residual current circuit breaker. Failure to do so could result in damage to the device and possibly injure the user.

Unplug the device before electrical storms occur and when it is unused for long periods of time to reduce the risk of electric shock or fire.

### 3 Features

The moving head is particularly suitable for professional lighting tasks, for example at events, on rock stages, in theatres and musicals or in discotheques.

Special features of the device:

- Control via DMX (17 channels) and via buttons and display on the unit
- PAN movement: 540°
- TILT movement: 270°
- PAN / TILT speed adjustable
- Ultra-high-speed stepper motors with 16 bit resolution
- Automatic position correction
- Colour wheel with 14 colours plus white
- Gobo wheel with 17 static gobos plus open
- Effects wheel with rotatable eightfold prism
- Motorized fine adjustable zoom / focus
- Shutter with programmed strobe effects
- Two Omega brackets with quick release fastener, two C-hooks and a safety cable included

## 4 Installation

Unpack and carefully check that there is no transportation damage before using the unit. Keep the equipment packaging. To fully protect the device against vibration, dust and moisture during transportation or storage use the original packaging or your own packaging material suitable for transport or storage, respectively.

Lift the device only at the base. When lifted at the rotatable mounting, the device may be damaged.

You can install the device standing or hanging. When in use, the device must be mounted at a solid surface or clamped to an approved truss.

Work from a stable platform whenever you install or move the device or when you perform any kind of maintenance. Block access under the work area.



## **WARNING!**

### **Risk of injury by falling off**

Make sure that the installation complies with the standards and rules that apply in your country. Always secure the device with a secondary safety attachment, such as a safety cable or a safety chain.

The carrying capacity of the truss or other mounting must be sufficient for the intended number of devices. Note that the movement of the head may additionally stress the load-bearing structures.

**CAUTION!****Risk of injury due to movements of the device**

The head of the device can move quickly (pan, tilt) and can produce very bright light. This is also valid immediately after you turn on the device, when the device operates in automatic mode or under remote control and when you turn off a DMX controller that is connected to the device. Persons staying near the device could be injured or frightened.

Before you turn on the device and during the operation, always ensure that nobody stays close to the device. If work has to be performed in the area of movement or in the near vicinity of the device, it must remain turned off.

**NOTICE!****Fire and overheating hazard**

The distance between the light source and flammable materials must be greater than 12 m. The distance to non-flammable materials must be greater than 2 m.

Always ensure sufficient ventilation.

The ambient temperature must always be below 40 °C (104 °F).



### **NOTICE!**

#### **Possible damage caused by movements of the device**

Always ensure that enough space is free around the device for the movements of the head (pan, tilt).



### **NOTICE!**

#### **Possible data transmission errors**

For error-free operation make use of dedicated DMX cables and do not use ordinary microphone cables.

Never connect the DMX input or output to audio devices such as mixers or amplifiers.



## Mounting options

The quick lock openings on the housing bottom are used for secure attachment of the included Omega brackets. To these, the flight adapters (such as the included C-hooks) are attached. The also included safety cable must pass through the notches on the bottom case as shown in the following figure.

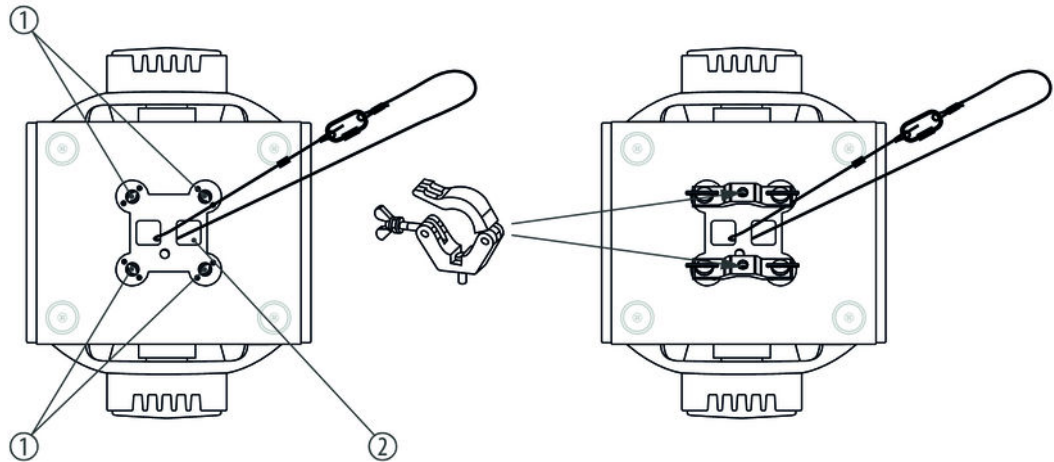

- |   |  |
|---|--|
| 1 | Quick lock openings for Omega brackets |
| 2 | Openings for safety rope               |

## 5 Starting up

Establish all connections as long as the unit is switched off. Use the shortest possible high-quality cables for all connections.

### Connections in DMX mode

Connect the DMX input of the device to the DMX output of a DMX controller or another DMX device. Connect the output of the first DMX device to the input of the second one, and so on to form a daisy chain. Always ensure that the output of the last DMX device in the daisy chain is terminated with a resistor ( $110\ \Omega$ ,  $\frac{1}{4}\text{ W}$ ).

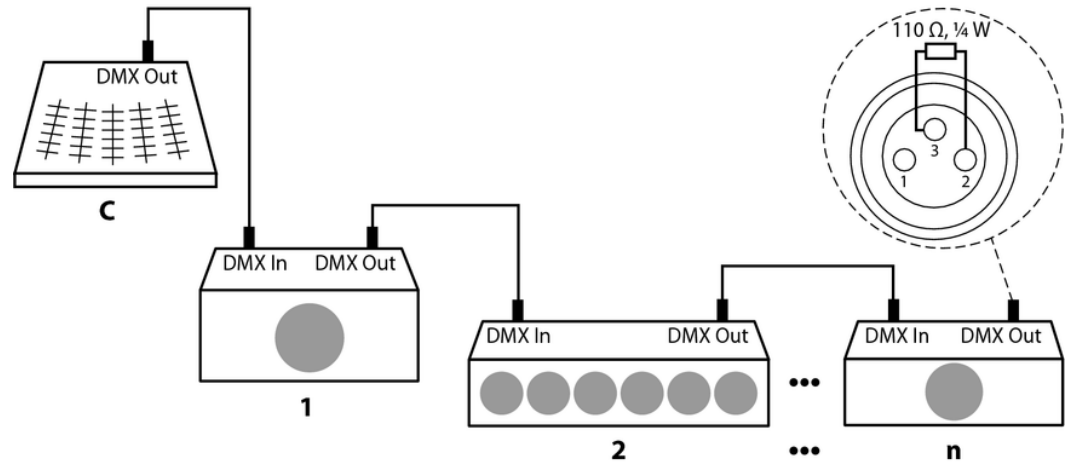

**DMX indicator**

When the unit and the DMX controller are in operation, the display shows the set DMX address continuously. This shows that a DMX signal is received at the input. If this is not the case, the set DMX address flashes on the display.

**Locking lever**

The two locking lever for rotation and inclination serve as transport safety device and protect the device from accidental movements. Lock both levers before you disassemble or transport the unit or when performing maintenance. Loosen both levers before turning on the device.

## 6 Connections and operating elements

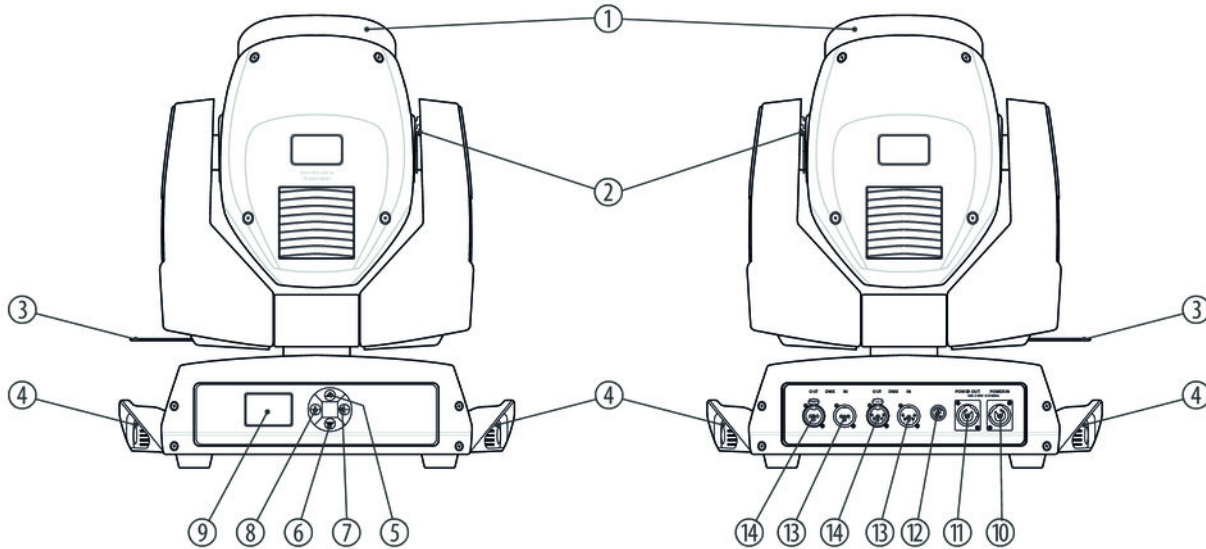

1	Light aperture.
2	Inclination locking lever.
3	Rotation locking lever.
4	Grab handle.
5	Arrow button ▲ Increases the displayed value by one.
6	Arrow button ▼ Decreases the displayed value by one. To reverse the display (for example when flying), press both arrow buttons briefly at the same time.
7	[E] Opens the main menu and submenus and serves to confirm the entered values.

8	<p><i>[S]</i></p> <p>Closes an open menu without saving any changes.</p> <p>If the display is shown inverted, the function of the keys <i>[E]</i> and <i>[S]</i> is interchanged.</p>
9	<p>Display.</p>
10	<p><i>[POWER IN]</i></p> <p>powerCON input for the voltage supply of the device. As soon as the power plug is connected to the power grid, voltage is present and the device is operational.</p>
11	<p><i>[POWER OUT]</i></p> <p>powerCON output for the power supply of another device.</p>
12	<p><i>[F 10A]</i></p> <p>Fuse holder.</p>
13	<p><i>[DMX IN]</i></p> <p>DMX input socket (3 and 5-pin).</p>
14	<p><i>[DMX OUT]</i></p> <p>DMX output socket (3 and 5-pin).</p>



## 7 Operating

### 7.1 Starting the device



#### **CAUTION!**

#### **Risk of injury due to movements of the device**

The head of the device can move quickly (pan, tilt) and can produce very bright light. This is also valid immediately after you turn on the device, when the device operates in automatic mode or under remote control and when you turn off a DMX controller that is connected to the device. Persons staying near the device could be injured or frightened.

Before you turn on the device and during the operation, always ensure that nobody stays close to the device. If work has to be performed in the area of movement or in the near vicinity of the device, it must remain turned off.

Loosen the locking levers for rotation and tilt.

Connect the device to the power grid to start the operation. After a few seconds, the fans start to work, the head moves to the home positions for rotation (pan) and inclination (tilt). After a few more seconds, the device operates in the last set mode. The last set DMX address appears in the display. About one minute after turning on the illuminant lights with full brightness.

## 7.2 Main menu

Press *[E]* to activate the main menu. Use the arrow buttons to select a submenu. When the display shows the desired submenu, press *[E]* to open it. To close the main menu, press *[S]* or wait for ten seconds.

All previous settings are retained even when you disconnect the device from the mains. To restart with default values, use the 'RESET' function.

**DMX address**

Press *[E]* to open the main menu. Then use the arrow buttons to select the menu item '*1.DMX AddressSet*'. Press *[E]*. Use the arrow buttons to select a value between 1 and 512. Use *[E]* to jump to the next digit of the numeric value.

When the display shows the desired value, press *[E]* to save the setting and close the submenu. To close the submenu without making changes, press *[S]* or wait a minute.

Make sure that the DMX address matches the configuration of your DMX controller.

**DMX mode**

Press *[E]* to open the main menu. Then use the arrow buttons to select the menu item '*2.Channel Mode*'. Press *[E]*. Now use the arrow buttons to select '*16*' (16 channel mode) or '*17*' (17 channel mode).

When the display shows the desired value, press *[E]* to save the setting and close the submenu. To close the submenu without making changes, press *[S]* or wait a minute.

**Operating hours display**

Press *[E]* to open the main menu. Then use the arrow buttons to select the menu item '*3.Info*'. Press *[E]*. Now use the arrow buttons to select the menu item '*1.Power On Times*'. Press *[E]*. Then use the arrow buttons to select the menu item '*1.Power On Time*'. Press *[E]*. The display now shows the unit's number of operating hours so far. The upper line shows the value since the last reset of the operating hours counter, the bottom line shows the total value since the production of the device.

Press *[S]* to exit the submenu or wait a minute.

### **Operating hours counter reset**

Press *[E]* to open the main menu. Then use the arrow buttons to select the menu item '*3.Info*'. Press *[E]*. Now use the arrow buttons to select the menu item '*1.Power On Times*'. Press *[E]*. Then use the arrow buttons to select the menu item '*2.Clear Time*'. Press *[E]*. Use the arrow buttons to select the option '*Confirm*' and press again *[E]*. The number of operating hours is reset, the display returns to the parent submenu.

Press *[S]* to exit the submenu or wait a minute.

### **Lamp hour counter**

Press *[E]* to open the main menu. Then use the arrow buttons to select the menu item '*3.Info*'. Press *[E]*. Now use the arrow buttons to select the menu item '*2.Lamp On Times*'. Press *[E]*. Then use the arrow buttons to select the menu item '*1.Lamp On Time*'. Press *[E]*. The display now shows the number of operating hours so far for the built-in illuminant. The upper line shows the value since the last reset of the lamp hours counter, the bottom line shows the total value since the production of the device.

Press *[S]* to exit the submenu or wait a minute.

**Lamp hours counter reset**

Press [E] to open the main menu. Then use the arrow buttons to select the menu item '3.Info'. Press [E]. Now use the arrow buttons to select the menu item '2.Lamp On Times'. Press [E]. Then use the arrow buttons to select the menu item '2.Clear Time'. Press [E]. Use the arrow buttons to select the option 'Confirm' and press again [E]. The number of lamp hours is reset, the display returns to the parent submenu.

Press [S] to exit the submenu or wait a minute.

**Lamp strike counter**

Press [E] to open the main menu. Then use the arrow buttons to select the menu item '3.Info'. Press [E]. Now use the arrow buttons to select the menu item '3.Lamp Strikes'. Press [E]. Then use the arrow buttons to select the menu item '1.Lamp Strike'. Press [E]. The display now shows the number of operating hours so far for the built-in illuminant. The upper line shows the value since the last reset of the lamp strike counter, the bottom line shows the total value since the production of the device.

Press [S] to exit the submenu or wait a minute.

**Lamp strike counter reset**

Press [E] to open the main menu. Then use the arrow buttons to select the menu item '3.Info'. Press [E]. Now use the arrow buttons to select the menu item '2.Lamp Strikes'. Press [E]. Then use the arrow buttons to select the menu item '2.Clear Time'. Press [E]. Use the arrow buttons to select the option 'Confirm' and press again [E] to confirm your selection and exit the Scene mode. The number of lamp strikes is reset, the display returns to the parent submenu.

Press [S] to exit the submenu or wait a minute.

## Software version

Press [E] to open the main menu. Then use the arrow buttons to select the menu item '3.Info'. Press [E]. Now use the arrow buttons to select the menu item '4.System Version'. Press [E]. The display now shows the software versions of the modules used.

Press [S] to exit the submenu or wait a minute.

## Fan speed

Press [E] to open the main menu. Then use the arrow buttons to select the menu item '3.Info'. Press [E]. Now use the arrow buttons to select the menu item '5.Fans Monitor'. Press [E]. The display now shows the speed of the two fans. The table below shows the values for normal operation. To avoid damage, turn off the appliance and let it cool down, if one or both speeds are above the limit.

Fan	Speed range (min <sup>-1</sup> )
Lamp fan 1	4500...5500
Lamp fan 2	3200...4000

Press [S] to exit the submenu or wait a minute.

**Pan inversion**

Press *[E]* to open the main menu. Then use the arrow buttons to select the menu item '*4.Options*'. Press *[E]*. Now use the arrow buttons to select the menu item '*1.Pan Inverse*'. Press *[E]*. Use the arrow buttons to select the option '*On*' (reverse rotation direction) or '*Off*' (normal rotation direction). Confirm the selection with *[E]*.

Press *[S]* to exit the submenu or wait a minute.

**Tilt inversion**

Press *[E]* to open the main menu. Then use the arrow buttons to select the menu item '*4.Options*'. Press *[E]*. Now use the arrow buttons to select the menu item '*2.Til Inverse*'. Press *[E]*. Use the arrow buttons to select the option '*On*' (reverse direction of inclination) or '*Off*' (normal direction of inclination). Confirm the selection with *[E]*.

Press *[S]* to exit the submenu or wait a minute.

**Pan Tilt swap**

Press *[E]* to open the main menu. Then use the arrow buttons to select the menu item '*4.Options*'. Press *[E]*. Now use the arrow buttons to select the menu item '*3.Pan Tilt Swap*'. Press *[E]*. Use the arrow buttons to select the option '*On*' (DMX channels for Pan and Tilt reversed) or '*Off*' (normal channel assignment). Confirm the selection with *[E]*.

Press *[S]* to exit the submenu or wait a minute.

### **Lamp strike via DMX**

Press *[E]* to open the main menu. Then use the arrow buttons to select the menu item *'4.Options'*. Press *[E]*. Now use the arrow buttons to select the menu item *'4.LampOn Via DMX'*. Press *[E]*. Use the arrow buttons to select the option *'On'* (lamp strike on present DMX signal) or *'Off'* (no automatic lamp strike). Confirm the selection with *[E]*.

Press *[S]* to exit the submenu or wait a minute.

### **Lamp off via DMX**

Press *[E]* to open the main menu. Then use the arrow buttons to select the menu item *'4.Options'*. Press *[E]*. Now use the arrow buttons to select the menu item *'5.LampOffVia DMX'*. Press *[E]*. Use the arrow buttons to select the option *'On'* (lamp off via DMX enabled) or *'Off'* (lamp off via DMX disabled). Confirm the selection with *[E]*.

Press *[S]* to exit the submenu or wait a minute.

### **Reset via DMX**

Press *[E]* to open the main menu. Then use the arrow buttons to select the menu item *'4.Options'*. Press *[E]*. Now use the arrow buttons to select the menu item *'6.Reset Via DMX'*. Press *[E]*. Use the arrow buttons to select the option *'On'* (reset via DMX enabled) or *'Off'* (reset via DMX disabled). Confirm the selection with *[E]*.

Press *[S]* to exit the submenu or wait a minute.



**Lamp strike when turning on**

Press [E] to open the main menu. Then use the arrow buttons to select the menu item '4.Options'. Press [E]. Now use the arrow buttons to select the menu item '7.LampOn byPowOn'. Press [E]. Use the arrow buttons to select the option 'On' (lamp strike when turning on) or 'Off' (no automatic lamp strike when turning on). Confirm the selection with [E].

Press [S] to exit the submenu or wait a minute.

**Lamps off when no DMX signal present**

Press [E] to open the main menu. Then use the arrow buttons to select the menu item '4.Options'. Press [E]. Now use the arrow buttons to select the menu item '8.LampOffifnoDMX'. Press [E]. Use the arrow buttons to select the option 'On' (lamp off when missing DMX signal) or 'Off' (lamp is on even with no DMX signal present). Confirm the selection with [E].

Press [S] to exit the submenu or wait a minute.

**Display language**

Press [E] to open the main menu. Then use the arrow buttons to select the menu item '5.Setting'. Press [E]. Now use the arrow buttons to select the menu item '1.Language'. Press [E]. Use the arrow buttons to select the option 'Simplified Chinese' or 'English'. Confirm the selection with [E].

Press [S] to exit the submenu or wait a minute.

### Display brightness

Press *[E]* to open the main menu. Then use the arrow buttons to select the menu item '*5.Setting*'. Press *[E]*. Now use the arrow buttons to select the menu item '*2.Display*'. Press *[E]* to confirm your selection and exit the Scene mode. Use the arrow buttons to select the menu item '*1.Brightness*'. Press *[E]*. Use the arrow buttons to select a value between 5 and 100.

When the display shows the desired value, press *[E]* to save the setting and close the submenu. To close the submenu without making changes, press *[S]* or wait a minute.

### Display mode

Press *[E]* to open the main menu. Then use the arrow buttons to select the menu item '*5.Setting*'. Press *[E]* to confirm your selection and exit the Scene mode. Now use the arrow buttons to select the menu item '*2.Display*'. Press *[E]* to confirm your selection and exit the Scene mode. Use the arrow buttons to select the menu item '*2.Light Mode*'. Press *[E]*. Use the arrow buttons to select the option '*Light Keep*' (display is permanently lit), '*Light Low*' (display is permanently dimmed) or '*Light Off*' (display is dimmed after an adjustable time). Confirm the selection with *[E]*.

Press *[S]* to exit the submenu or wait a minute.

### Display turn-off time

Press *[E]* to open the main menu. Then use the arrow buttons to select the menu item '*5.Setting*'. Press *[E]*. Now use the arrow buttons to select the menu item '*2.Display*'. Press *[E]*. Use the arrow buttons to select the menu item '*3.Light time*'. Press *[E]*. Use the arrow buttons to select a value between 5 and 60 seconds. If the display mode is set to '*Off*', the display is automatically dimmed after the set time.

When the display shows the desired value, press *[E]* to save the setting and close the submenu. To close the submenu without making changes, press *[S]* or wait a minute.

### Display reversal

To reverse the display (for example when flying), press both arrow buttons briefly at the same time. Alternatively, you can also use the corresponding menu item:

Press *[E]* to open the main menu. Then use the arrow buttons to select the menu item '*5.Setting*'. Press *[E]*. Now use the arrow buttons to select the menu item '*2.Display*'. Press *[E]*. Use the arrow buttons to select the menu item '*4.Disp Inversion*'. Press *[E]*. Use the arrow buttons to select the option '*ON*' (display reversed) or '*OFF*' (display in normal direction). Confirm the selection with *[E]*.

When the display shows the desired value, press *[E]* to save the setting and close the submenu. To close the submenu without making changes, press *[S]* or wait a minute.

If the display is shown inverted, the function of the keys *[E]* and *[S]* is interchanged.

### **Reset to factory defaults**

Press [E] to open the main menu. Then use the arrow buttons to select the menu item *'5.Setting'*. Press [E] to confirm your selection and exit the Scene mode. Now use the arrow buttons to select the menu item *'3.Factory Set'*. Use the arrow buttons to select the option *'Confirm'* and press again [E].

### **Lamp strike**

Press [E] to open the main menu. Then use the arrow buttons to select the menu item *'6.Manual Control'*. Press [E]. Now use the arrow buttons to select the menu item *'1.Lamp On Or Off'*. Press [E]. Use the arrow buttons to select the option *'Lamp On'* or *'Lamp Off'*. Confirm the selection with [E].

### **Total reset**

Press [E] to open the main menu. Then use the arrow buttons to select the menu item *'6.Manual Control'*. Press [E]. Now use the arrow buttons to select the menu item *'2.Reset Function'*. Press [E]. Use the arrow buttons to select the menu item *'Reset All'*. Press [E].

### **Effects reset**

Press [E] to open the main menu. Then use the arrow buttons to select the menu item *'6.Manual Control'*. Press [E]. Now use the arrow buttons to select the menu item *'2.Reset Function'*. Press [E]. Use the arrow buttons to select the menu item *'Reset Effect'*. Press [E].

**Pan and Tilt reset**

Press [E] to open the main menu. Then use the arrow buttons to select the menu item '6.Manual Control'. Press [E]. Now use the arrow buttons to select the menu item '2.Reset Function'. Press [E]. Use the arrow buttons to select the menu item 'Reset Pan/Tilt'. Press [E].

**DMX value display.**

Press [E] to open the main menu. Then use the arrow buttons to select the menu item '7.Test'. Press [E]. The display now shows for each DMX channel the transmitted value.

Press [S] to exit the submenu or wait a minute.

**Settings menu**

The settings menu (menu item '8.Advanced') is accessible only for manufacturer and customer service.

## 7.3 Gobos

The following figure shows the available gobos as well as their numbers.

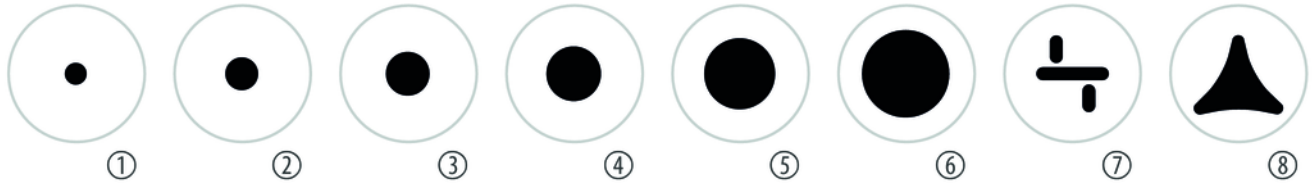

## 7.4 Menu overview

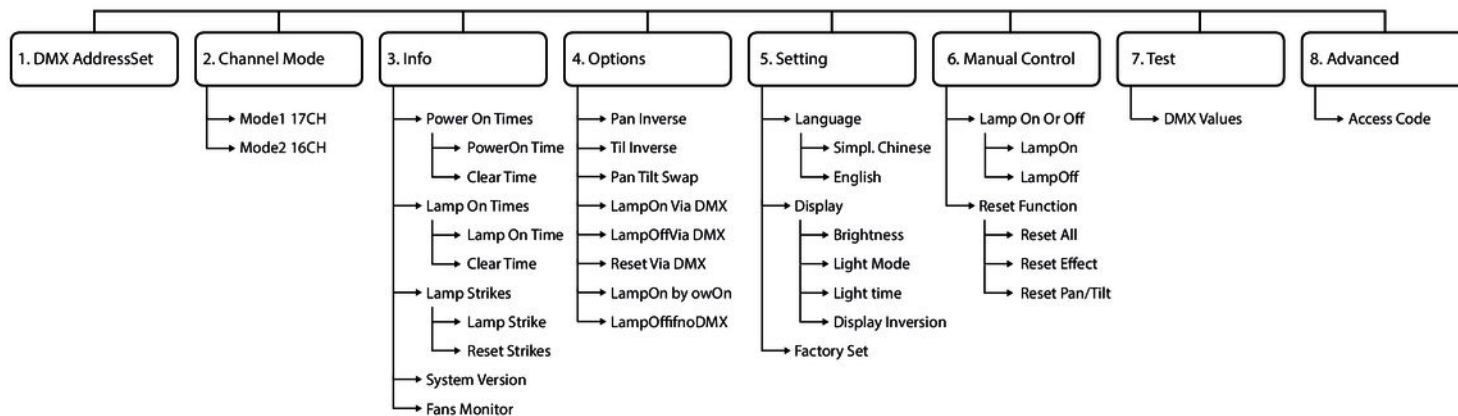

## 7.5 Functions in 16-channel DMX mode

Channel	Value	Function
1	Colour wheel	
	0 ... 4	White
	5 ... 8	White + red
	9 ... 12	Red
	13 ... 17	Red + orange
	18 ... 21	Orange
	22 ... 25	Orange + cyan
	26 ... 29	Cyan
	30 ... 34	Cyan + green
	35 ... 38	Green
	39 ... 42	Green + light green



Channel	Value	Function
	43 ... 46	Light green
	47 ... 51	Light green + lavender
	52 ... 55	Lavender
	56 ... 59	Lavender + light yellow
	60 ... 63	Light yellow
	64 ... 68	Light yellow + yellow
	69 ... 72	Yellow
	73 ... 76	Yellow + pink
	77 ... 81	Pink
	82 ... 85	Pink + blue
	86 ... 89	Blue
	90 ... 93	Blue + CTO260
	94 ... 98	CTO260

Channel	Value	Function
	99 ... 102	CTO260 + CTO190
	103 ... 106	CTO190
	107 ... 110	CTO190 + CTB800
	111 ... 115	CTB800
	116 ... 119	CTB800 + UV
	120 ... 123	UV
	124 ... 127	UV + white
	128 ... 188	Clockwise rotation, decreasing speed
	189 ... 255	Anti-clockwise rotation, decreasing speed
2	Strobe effect	
	0 ... 1	No strobe effect, lamp off
	2 ... 7	No strobe effect, lamp on
	8 ... 63	Strobe effect (standard), increasing speed

Channel	Value	Function
	64 ... 71	No strobe effect, lamp on
	72 ... 127	Strobe effect (symmetrical), increasing speed
	128 ... 135	No strobe effect, lamp on
	136 ... 160	Strobe effect (fast shutter), increasing speed
	161 ... 166	No strobe effect, lamp on
	167 ... 191	Strobe effect, increasing speed
	192 ... 199	No strobe effect, lamp on
	200 ... 209	Effect 1
	210 ... 219	Effect 2
	220 ... 229	Random, slow strobe effect
	230 ... 239	Random strobe effect with medium speed
	240 ... 249	Random strobe effect, decreasing speed
	250 ... 255	No strobe effect, lamp on

Channel	Value	Function
3	0 ... 255	Mechanical dimmer (100 % to 0 %)
4	Gobos	
	0 ... 3	White
	4 ... 7	Gobo 1
	8 ... 11	Gobo 2
	12 ... 15	Gobo 3
	16 ... 19	Gobo 4
	20 ... 23	Gobo 5
	24 ... 27	Gobo 6
	28 ... 31	Gobo 7
	32 ... 35	Gobo 8
	36 ... 39	Gobo 9
40 ... 43	Gobo 10	

Channel	Value	Function
	44 ... 47	Gobo 11
	48 ... 51	Gobo 12
	52 ... 55	Gobo 13
	56 ... 59	Gobo 14
	60 ... 63	Gobo 15
	64 ... 67	Gobo 16
	68 ... 71	Gobo 17
	72 ... 113	Gobo wheel rotation anti-clockwise, decreasing speed
	114 ... 117	Gobo wheel stopped
	118 ... 159	Gobo wheel rotation clockwise, increasing speed
	160 ... 166	Gobo 2 shake, increasing speed
	167 ... 172	Gobo 3 shake, increasing speed
	173 ... 179	Gobo 4 shake, increasing speed

Channel	Value	Function
	180 ... 185	Gobo 5 shake, increasing speed
	186 ... 191	Gobo 6 shake, increasing speed
	192 ... 198	Gobo 7 shake, increasing speed
	199 ... 204	Gobo 8 shake, increasing speed
	205 ... 211	Gobo 9 shake, increasing speed
	212 ... 217	Gobo 10 shake, increasing speed
	218 ... 223	Gobo 11 shake, increasing speed
	224 ... 230	Gobo 12 shake, increasing speed
	231 ... 236	Gobo 13 shake, increasing speed
	237 ... 248	Gobo 14 shake, increasing speed
	249 ... 249	Gobo 15 shake, increasing speed
250 ... 255	Gobo 16 shake, increasing speed	
5	Prism	

Channel	Value	Function
	0 ... 127	Prism off
	128 ... 255	Prism on
6	Prism Rotation	
	0 ... 127	Index position 0° to 540°
	128 ... 190	Anti-clockwise rotation, decreasing speed
	191 ... 192	No rotation
	193 ... 255	Clockwise rotation, increasing speed
7	0 ... 255	Prism zoom
8	0 ... 255	Frost
9	0 ... 255	Focus (near... far)
10	0 ... 255	Rotation (pan) (0° to 540°) in increments of 2.12°
11	0 ... 255	Fine adjustment of rotation in increments of 0.008°
12	0 ... 255	Inclination (pan) (0° to 540°) in increments of 0.98°

Channel	Value	Function
13	0 ... 255	Fine adjustment of inclination in increments of 0.004°
14	No function	
15	Reset	
	0 ... 25	No function
	26 ... 76	Colour wheel, gobo wheel and lens reset
	77 ... 127	Rotation and inclination reset
	128 ... 255	Total reset
16	Switching lamp on and off	
	0 ... 25	No function
	26 ... 100	Switching lamp off after five seconds
	101 ... 255	Switching lamp on after five seconds



## 7.6 Functions in 17-channel DMX mode

Channel	Value	Function
1	0...255	Rotation (pan) (0° to 540°) in increments of 2.12°
2	0...255	Fine adjustment of rotation in increments of 0.008°
3	0...255	Inclination (pan) (0° to 540°) in increments of 0.98°
4	0...255	Fine adjustment of inclination in increments of 0.004°
5	Rotation and inclination speed	
	0	Maximum speed
	1...250	Linear speed reduction
	251...255	Maximum speed
6	Colour wheel	
	0...4	White
	5...8	White + red

Channel	Value	Function
	9...12	Red
	13...17	Red + orange
	18...21	Orange
	22...25	Orange + cyan
	26...29	Cyan
	30...34	Cyan + green
	35...38	Green
	39...42	Green + light green
	43...46	Light green
	47...51	Light green + lavender
	52...55	Lavender
	56...59	Lavender + light yellow
	60...63	Light yellow

Channel	Value	Function
	64...68	Light yellow + yellow
	69...72	Yellow
	73...76	Yellow + pink
	77...81	Pink
	82...85	Pink + blue
	86...89	Blue
	90...93	Blue + CTO260
	94...98	CTO260
	99...102	CTO260 + CTO190
	103...106	CTO190
	107...110	CTO190 + CTB800
	111...115	CTB800
	116...119	CTB800 + UV

Channel	Value	Function
	120...123	UV
	124...127	UV + white
	128...188	Rotation clockwise, decreasing speed
	189...255	Rotation counterclockwise, decreasing speed
7	Strobe effect	
	0...1	No strobe effect, lamp off
	2...7	No strobe effect, lamp on
	8...63	Strobe effect (standard), increasing speed
	64...71	No strobe effect, lamp on
	72...127	Strobe effect (symmetrical), increasing speed
	128...135	No strobe effect, lamp on
	136...160	Strobe effect (fast shutter), increasing speed
161...166	No strobe effect, lamp on	

Channel	Value	Function
	167...191	Strobe effect, increasing speed
	192...199	No strobe effect, lamp on
	200...209	Effect 1
	210...219	Effect 2
	220...229	Random slow strobe effect
	230...239	Random strobe effect with medium speed
	240...249	Random strobe effect with decreasing speed
	250...255	No strobe effect, lamp on
8	0...255	Mechanical dimmer (100 % to 0 %)
9	Gobos	
	0...3	White
	4...7	Gobo 1
	8...11	Gobo 2

Channel	Value	Function
	12...15	Gobo 3
	16...19	Gobo 4
	20...23	Gobo 5
	24...27	Gobo 6
	28...31	Gobo 7
	32...35	Gobo 8
	36...39	Gobo 9
	40...43	Gobo 10
	44...47	Gobo 11
	48...51	Gobo 12
	52...55	Gobo 13
	56...59	Gobo 14
	60...63	Gobo 15

Channel	Value	Function
	64...67	Gobo 16
	68...71	Gobo 17
	72...113	Gobo wheel rotation counterclockwise, decreasing speed
	114...117	Gobo wheel stopped
	118...159	Rotation of the gobo wheel clockwise, increasing speed
	160...166	Gobo 2 shake, increasing speed
	167...172	Gobo 3 shake, increasing speed
	173...179	Gobo 4 shake, increasing speed
	180...185	Gobo 5 shake, increasing speed
	186...191	Gobo 6 shake, increasing speed
	192...198	Gobo 7 shake, increasing speed
	199...204	Gobo 8 shake, increasing speed
	205...211	Gobo 9 shake, increasing speed

Channel	Value	Function
	212...217	Gobo 10 shake, increasing speed
	218...223	Gobo 11 shake, increasing speed
	224...230	Gobo 12 shake, increasing speed
	231...236	Gobo 13 shake, increasing speed
	237...248	Gobo 14 shake, increasing speed
	249...249	Gobo 15 shake, increasing speed
	250...255	Gobo 16 shake, increasing speed
10	0...255	Frost
11	Reset	
	0...25	Without function
	26...76	Colour wheel, gobo wheel and lens reset
	77..127	Rotation and inclination reset
	128...255	Total reset



Channel	Value	Function
12	0...255	Focus (close ... far)
13	Switching lamp on and off	
	0...25	Without function
	26...100	Switching lamp off after five seconds
	101...255	Switching lamp on after five seconds
14	Prism	
	0...127	Prism off
	128...255	Prism on
15	Prism rotation	
	0...127	Index position 0° to 540°
	128...190	Gobo wheel rotation clockwise, decreasing speed
	191...192	No rotation
	193...255	Rotation clockwise, increasing speed

Channel	Value	Function
16	0...255	Prism zoom
17	Without function	

## 8 Maintenance

### 8.1 Installing / replacing the illuminant



**DANGER!**

**Electric shock caused by high voltages inside**

Within the device there are areas where high voltages may be present.

Completely disconnect the device from the power supply before you open or remove covers. Mount all covers and attach them firmly before connecting the device again.



### **WARNING!**

#### **Risk of burns at the surface and inside of the device**

The surface and the inner parts of the device can become very hot during operation.

After switching off the device wait for at least 15 minutes before you start any maintenance activities.



### **WARNING!**

#### **Danger of burns in case of inappropriate handling of the illuminant**

The light source used in this device is under high pressure, especially when heated, and can explode if handled inappropriately.

Allow the illuminant to cool down for at least two hours before starting any maintenance or replacement. Always wear suitable protective gloves and safety glasses when handling the illuminant.



**WARNING!**

**Danger of poisoning on lamp breakage**

When discharge lamps break, small amounts of harmful substances (e.g. mercury) are released.

When a discharge lamp breaks within a closed room: Vacate the room immediately and ventilate adequately.

To remove the remnants of broken discharge lamps wear Nitrile protective gloves, breathing and mouth protection.

Dispose of broken or worn discharge lamps as hazardous waste according to legal regulations in a tightly closed container.



### **WARNING!**

#### **Danger of burns and eye injuries caused by high light intensity**

The light source used in this device produces visible and invisible light beams of high intensity.

Never look directly into the light source.

Do not use the device when covers, shieldings, lenses or other optical components are missing or damaged. In particular, avoid prolonged direct exposure of the skin during maintenance without adequate cover of the light source.



### **CAUTION!**

#### **Danger of injury in case of inappropriate handling of the illuminant**

After the specified lifetime of the used illuminant there is an increased risk of explosion.

Replace the illuminant in time, latest at the end of rated average lifetime.

When replacing the illuminant, all safety instructions for handling light sources must be observed and wear suitable protective gloves and safety glasses.

**NOTICE!****Possible damages due to dirt or finger prints**

Due to the high temperatures, even smallest pieces of dirt on the bulb can destroy the lamp when it is turned on.

Do not touch the lamp directly with your fingers. Use clean gloves or a clean lint-free tissue.

**NOTICE!****Possible damages due to wrong type of lamp**

Any attempt to use the device with a lamp other than those specified in this manual can result in severe damages to the device.

Only use a lamp of the specified type.

**Notes on the illuminant**

The device may only be operated with an illuminant of the type 'Philips MSD Platinum 5R' for use in stage and theatre area. Observe the safety instructions of the illuminant manufacturer.

### Required tools

- Phillips screwdriver size PH1
- Allen key size SW 3
- Flat pliers

### Procedure

1. ➤ Make sure that the device is turned off, disconnected from the mains and completely cooled down.
2. ➤ Move the head of the unit in a horizontal position. The label 'Open this side to change lamp' must be at the top. Secure the head with both locking levers against rotation.



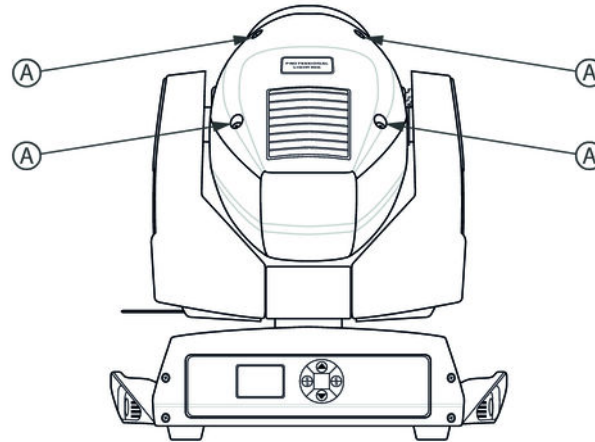

3. ➤ Open the housing by unscrewing the four Phillips top screws marked in the illustration above by 'A' and remove the upper part of the housing. Make sure that no screw falls inside the unit.

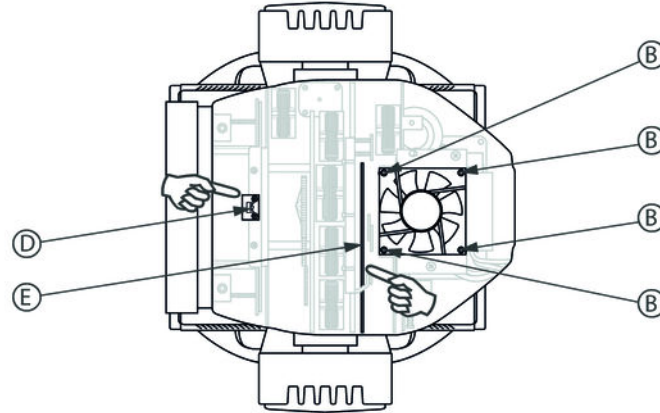

4. ➤ Check that you have removed the proper cover. Compare the exposed interior of the unit with the illustration. If you can see the heat sensor (marked in the illustration by 'D') at this point, the proper side of the case has been opened. If the correct side of the case is open, you can also clearly see the colour wheel (in the figure marked by 'E').

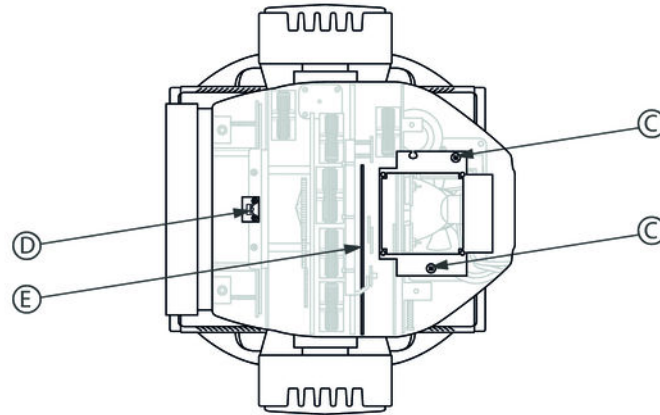

- 5.** ➤ Loosen the two Phillips screws holding the illuminant cover (marked in the illustration by 'C') and remove the illuminant cover.
- 6.** ➤ Press the illuminant against the spring tension down and tilt it so far back, until you can remove it upwards out of the holder.
- 7.** ➤ Unplug the two flat connectors with the pliers from the old illuminant.
- 8.** ➤ Connect the two flat connectors to the new illuminant. Secure the new illuminant using the spring clips. Check the secure fit.

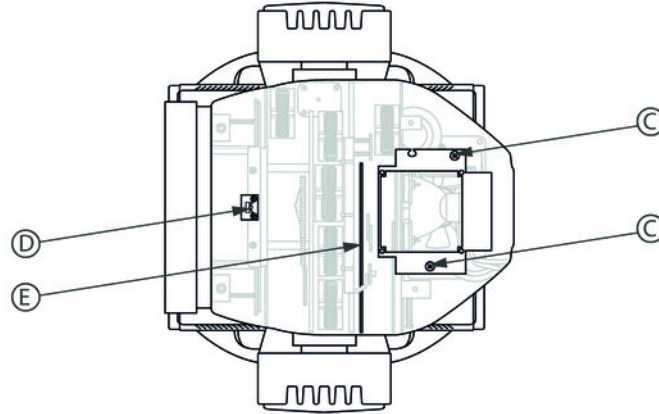

- 9.** ➤ Reattach the illuminant cover and secure it with the two Phillips screws (marked in the illustration by 'C').

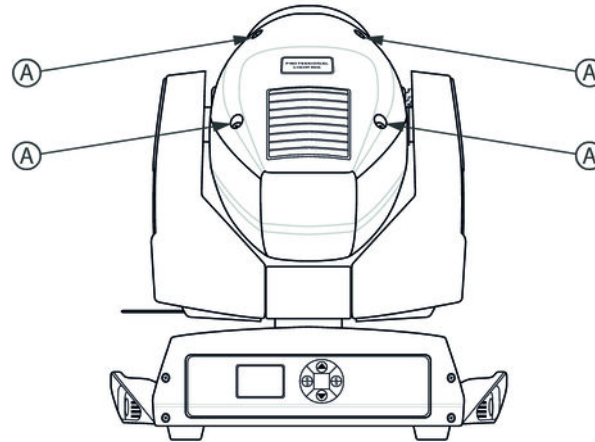

- 10.** Put the upper part of the housing back on the base. At that point, both housing parts must engage in the circumferential seal profile. Replace the four Phillips screws ('A') to the top of the housing and tighten them.

## 8.2 Lamp hour counter reset

We recommend to reset the operating hours counter for the illuminant and the counter for the lamp strikes after each replacement to zero. This allows you to observe the operating hours of the illuminant at any time ( ↪ *'Lamp hours counter reset' on page 37*).

## 9 Technical specifications

Number of DMX channels	17
Illuminant	Philips MSD Platinum 5R
Dispersion angle	0.6°...4.0°
Maximum rotation angle (pan)	540°
Maximum inclination angle (tilt)	270°
Dimmer	0 ... 100 %, linear
Strobe / shutter	0 ... 13 Hz
Operating supply voltage	AC 230 V ~ , 50 Hz
Power consumption	230 W
Equipment class	IP20
Dimensions (W × H × D)	39 cm × 48,5 cm × 33 cm
Weight	19.5 kg

## 10 Plug and connection assignment

### Introduction

This chapter will help you select the right cables and plugs to connect your valuable equipment so that a perfect light experience is guaranteed.

Please take our tips, because especially in 'Sound & Light' caution is indicated: Even if a plug fits into a socket, the result of an incorrect connection may be a destroyed DMX controller, a short circuit or 'just' a not working light show!

### DMX connections

The unit offers a 3-pin XLR socket for DMX output and a 3-pin XLR plug for DMX input. Please refer to the drawing and table below for the pin assignment of a suitable XLR plug.



Pin	Configuration
1	Ground, shielding
2	Signal inverted (DMX-, 'cold signal')
3	Signal (DMX+, 'hot signal')



## 11 Troubleshooting



### **NOTICE!**

#### **Possible data transmission errors**

For error-free operation make use of dedicated DMX cables and do not use ordinary microphone cables.

Never connect the DMX input or output to audio devices such as mixers or amplifiers.

In the following we list a few common problems that may occur during operation. We give you some suggestions for easy troubleshooting:

Symptom	Remedy
The unit does not work, no light, the fan does not run	Check the mains connection and the main fuse.
No response to the DMX controller	1. The set DMX address should appear continuously in the display. If the address flashes in the display, check the DMX connectors and cables for correct connection.
	2. If the set DMX address is displayed continuously but there is still no response, check the address settings and DMX polarity.
	3. Try using another DMX controller.
	4. Check to see if the DMX cables run near or alongside to high voltage cables that may cause damage or interference to DMX interface circuits.

If the procedures recommended above do not succeed, please contact our Service Center. You can find the contact information at [www.thomann.de](http://www.thomann.de).

## 12 Cleaning

### Optical lenses

Clean the optical lenses, that are accessible from the outside, regularly in order to optimize the light output. The frequency of cleaning depends on the operating environment: wet, smoky or particularly dirty surroundings can cause more accumulation of dirt on the optics of the device.

- Clean with a soft cloth using our lamp and lens cleaner (item no. 280122).
- Always dry the parts carefully.

### Fan grids

The fan grids of the device must be cleaned on a regular basis to remove dust and dirt. Before cleaning, switch off the device and disconnect AC-powered devices from the mains. Use a lint-free damp cloth for cleaning. Never use solvents or alcohol for cleaning.

## 13 Protecting the environment

### Disposal of the packaging material



For the packaging, environmentally friendly materials have been chosen that can be supplied to normal recycling.

Ensure that plastic bags, packaging, etc. are properly disposed of.

Do not just dispose of these materials with your normal household waste, but make sure that they are collected for recycling. Please follow the notes and markings on the packaging.

### Disposal of your old device



This product is subject to the European Waste Electrical and Electronic Equipment Directive (WEEE) in its currently valid version. Do not dispose with your normal household waste.

Dispose of this device through an approved waste disposal firm or through your local waste facility. When discarding the device, comply with the rules and regulations that apply in your country. If in doubt, consult your local waste disposal facility.

**Dispose of discharge lamps**

Dispose of broken or worn discharge lamps as hazardous waste according to legal regulations in a tightly closed container.





Musikhaus Thomann · Hans-Thomann-Straße 1 · 96138 Burgebrach · Germany · [www.thomann.de](http://www.thomann.de)